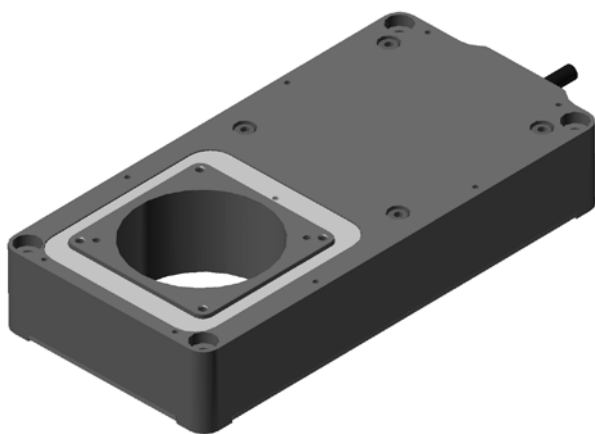


PZ247E P-63x Positioning Systems User Manual

Version: 1.0.0

Date: 20.09.2013



This document describes the following products:

- **P-630.XCD**
Linear Piezo Nanopositioning System with Large Aperture, 40 μm , Direct Metrology, Capacitive Sensor
- **P-631.XCD**
Linear Piezo Nanopositioning System with Large Aperture, 80 μm , Direct Metrology, Capacitive Sensor



Physik Instrumente (PI) GmbH & Co. KG is the owner of the following trademarks:
PI®, PIC®, PICMA®, PILine®, PIFOC®, PiezoWalk®, NEXACT®, NEXLINE®,
NanoCube®, NanoAutomation®, Picoactuator®, PInano®

The products described in this document are in part protected by the following patents:

German patent no. 10021919C2

German patent no. 10234787C1

German patent no. 10348836B3

German patent no. 102005015405B3

German patent no. 102007011652B4

US patent no. 7,449,077

Japanese patent no. 4667863

Chinese patent no. ZL03813218.4

© 2013 Physik Instrumente (PI) GmbH & Co. KG, Karlsruhe, Germany. The text, photographs and drawings in this manual are protected by copyright. With regard thereto, Physik Instrumente (PI) GmbH & Co. KG retains all the rights. Use of said text, photographs and drawings is permitted only in part and only upon citation of the source.

Original instructions

First printing: 20.09.2013

Document number: PZ247E, CBo, Version 1.0.0

Subject to change without notice. This manual is superseded by any new release. The latest release is available for download (p. 3) on our website.



Contents

1	About this Document	1
1.1	Goal and Target Audience of this User Manual	1
1.2	Symbols and Typographic Conventions	1
1.3	Other Applicable Documents	2
1.4	Downloading Manuals	3
2	Safety	5
2.1	Intended Use	5
2.2	General Safety Instructions	5
2.3	Organizational Measures	6
3	Product Description	7
3.1	Model Overview	7
3.2	Product View	8
3.3	Scope of Delivery	9
3.4	Recommended Piezo Controllers	9
3.5	Technical Features	10
3.5.1	PICMA® Piezo Actuators	10
3.5.2	Flexure Guides	10
3.5.3	Capacitive Sensors	10
3.5.4	ID Chip	10
4	Unpacking	11
5	Installation	13
5.1	General Notes on Installation	13
5.2	Connecting the P-63x to the Protective Earth Conductor	15
5.3	Mounting the P-63x	17
5.4	Affixing the Load	19
6	Start-Up and Operation	23
6.1	General Notes on Start-Up and Operation	23
6.2	Operating the P-63x	25
6.3	Discharging the P-63x	25

7	Maintenance	27
7.1	General Notes on Maintenance	27
7.2	Cleaning the P-63x	27
8	Troubleshooting	29
9	Customer Service	31
10	Technical Data	33
10.1	Specifications	33
10.1.1	Data Table	33
10.1.2	Maximum Ratings	34
10.1.3	Ambient Conditions and Classifications	35
10.2	Dimensions	36
10.3	Torque for Stainless Steel Screws (A2-70)	36
10.4	Pin Assignment	37
11	Old Equipment Disposal	39
12	EC Declaration of Conformity	41

1 About this Document

In this Chapter

Goal and Target Audience of this User Manual	1
Symbols and Typographic Conventions	1
Other Applicable Documents	2
Downloading Manuals	3

1.1 Goal and Target Audience of this User Manual

This user manual contains the necessary information for the intended use of the P-63x (x stands for the different models, p. 7).

Basic knowledge of control technology, drive technologies and suitable safety measures is assumed.

The latest versions of the user manuals are available for download (p. 3) on our website.

1.2 Symbols and Typographic Conventions

The following symbols and typographic conventions are used in this user manual:

CAUTION



Dangerous situation

If not avoided, the dangerous situation will result in minor injury.



- Actions to take to avoid the situation.

NOTICE



Dangerous situation

If not avoided, the dangerous situation will result in damage to the equipment.

- Actions to take to avoid the situation.

INFORMATION

Information for easier handling, tricks, tips, etc.

Symbol/Label	Meaning
1.	Action consisting of several steps whose sequential order must be observed
2.	
➤	Action consisting of one or several steps whose sequential order is irrelevant
▪	List item
p. 5	Cross-reference to page 5
RS-232	Labeling of an operating element on the product (example: socket of the RS-232 interface)
	Warning signs affixed to the product that refer to detailed information in this manual.

1.3 Other Applicable Documents

The devices and software tools which are mentioned in this documentation are described in their own manuals.

Device	Document
E-625.CR piezo servo controller	PZ166E User Manual
E-665.CR piezo servo controller	PZ127E User Manual
E-609.C0 OEM piezo controller	E609T0001 Technical Note
E-709 digital piezo controller	PZ222E User Manual
E-709.CRG / E-709.CR / E-709.CHG digital piezo controller	E709T0003 Technical Note
E-753 digital piezo controller	PZ193E User Manual
E-712 digital multi-channel piezo controller	PZ195E User Manual
E-725 digital multi-channel piezo controller	PZ197E User Manual
E-761 digital multi-channel piezo controller (PCI board)	PZ164E User Manual
P-5xx / P-6xx / P-7xx piezo positioning systems	PZ240EK Short Instructions

1.4 Downloading Manuals

INFORMATION

If a manual is missing on our website or if there are problems in downloading:

- Contact our customer service department (p. 31).

The current versions of the manuals are found on our website. Access to the manuals of Hexapod systems and electronics whose scope of delivery includes a CD is password-protected. The password is stored on the CD.

Download freely accessible manuals

1. Open the website <http://www.pi-portal.ws>.
2. Click **Downloads**.
3. Click the corresponding category (e. g. **P Piezo Actuators, Nanopositioning & Scanning Systems**).
4. Click the corresponding product code (e. g. **P-630**).
5. Click **Documents**.

The available manuals are displayed.

6. Click the desired manual and save it on the hard disk of your PC or on a data storage medium.

Download password-protected manuals

1. Carry out steps 1 to 5 of the download process for freely accessible manuals.
2. Insert the product CD in the PC drive.
3. Switch to the **Manuals** directory on the CD.
4. In the **Manuals** directory, open the Release News (file including **releasenews** in the file name).
5. Find the user name and password in the **User login for software download** section in the Release News.
6. In the **User login** area on the left margin in the website, enter the user name and the password in the corresponding fields.
7. Click **Login**.

The available manuals are displayed.

8. Click the desired manual and save it on the hard disk of your PC or on a data storage medium.

2 Safety

In this Chapter

Intended Use	5
General Safety Instructions	5
Organizational Measures.....	6

2.1 Intended Use

The P-63x is a laboratory device as defined by DIN EN 61010-1. It is intended to be used in interior spaces and in an environment which is free of dirt, oil, and lubricants.

Based on its design and realization, the P-63x is intended for fine positioning as well as the fast and precise motion of small objects. The motion takes place linearly in one axis. The specifications of the P-63x apply to horizontal mounting. Vertical mounting is only possible under certain conditions (p. 17).

The intended use of the P-63x is only possible in combination with suitable electronics (p. 9) that is available from PI. The electronics is not included in the scope of delivery of the P-63x.

The electronics must provide the required operating voltages. To ensure proper performance of the servo-control system, the electronics must be able to read out and process the signals from the capacitive sensors.

2.2 General Safety Instructions

The P-63x is built according to state-of-the-art technology and recognized safety standards. Improper use can result in personal injury and/or damage to the P-63x.

- Only use the P-63x for its intended purpose, and only use it if it is in a good working order.
- Read the user manual.
- Immediately eliminate any faults and malfunctions that are likely to affect safety.

The operator is responsible for the correct installation and operation of the P-63x.

Mechanical forces can damage or misalign the P-63x.

- Avoid impacts that affect the P-63x.
- Do **not** drop the P-63x.
- Do **not** exceed the maximum permissible stress and load capacities according to the specifications (p. 33).
- Only hold the P-63x externally by the base body.

The P-63x is maintenance-free and achieves its positioning accuracy as a result of the optimum alignment of mechanical components and piezo actuators. Loosened screws cause a loss in positioning accuracy.

- Only loosen screws according to the instructions in this manual.
- Do **not** open the P-63x.

2.3 Organizational Measures

User manual

- Always keep this user manual available by the P-63x.
The latest versions of the user manuals are available for download (p. 3) on our website.
- Add all information given by the manufacturer to the user manual, for example supplements or Technical Notes.
- If you pass the P-63x on to other users, also turn over this user manual as well as other relevant information provided by the manufacturer.
- Only use the device on the basis of the complete user manual. Missing information due to an incomplete user manual can result in minor injury and property damage.
- Only install and operate the P-63x after having read and understood this user manual.

Personnel qualification

The P-63x may only be installed, started up, operated, maintained and cleaned by authorized and appropriately qualified personnel.

3 Product Description

In this Chapter

Model Overview	7
Product View	8
Scope of Delivery	9
Recommended Piezo Controllers.....	9
Technical Features	10

3.1 Model Overview

The P-63x is available in the following versions:

Model	Description
P-630.XCD	Linear piezo nanopositioning system with large aperture, 40 μm , direct metrology, capacitive sensor
P-631.XCD	Linear piezo nanopositioning system with large aperture, 80 μm , direct metrology, capacitive sensor

3.2 Product View

The figure serves as an example and can differ from your stage model.

- Observe the symbols on your device.

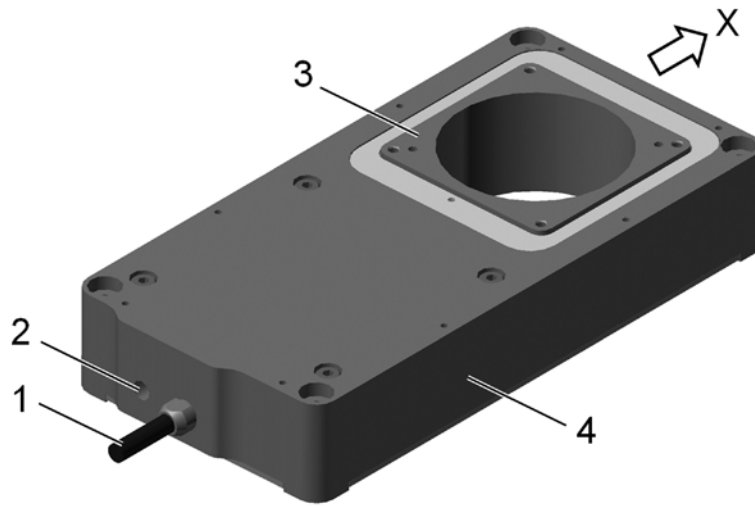


Figure 1: Example of product view

- 1 Connection cable to the electronics
- 2 Protective earth connection
- 3 Moving platform
- 4 Base body
- x (Positive) direction of motion of the stage

3.3 Scope of Delivery

Order Number	Items
P-63x	Stage according to order (p. 7)
000036450	M4 screw set for protective earth, consisting of: <ul style="list-style-type: none"> ▪ 1 M4x8 flat-head screw with cross recess, ISO 7045 ▪ 2 safety washers ▪ 2 flat washers
000044620	Screw set: <ul style="list-style-type: none"> ▪ 4 M2.5x20 hex-head cap screws, ISO 4762 ▪ 1 Allen wrench
PZ240EK	Short instructions for piezo positioning systems

3.4 Recommended Piezo Controllers

To operate a P-63x, you need a piezo controller. The device is selected depending on the type of application. The table below lists suitable controllers.

Controller	Description	Channels
E-625.CR	Piezo amplifier / servo controller (bench-top)	1
E-665.CR	Piezo amplifier / servo controller (bench-top)	1
E-609.C0	OEM piezo controller	1
E-709.CRG E-709.CR E-709.CHG	Digital piezo controller	1
E-753	Digital piezo controller (bench-top)	1
E-712*	Digital piezo controller (modular system)	3/6
E-725*	Digital piezo controller (bench-top)	3
E-761*	Digital piezo controller (PCI board)	3

* E-710.3D0 adapter cable required (must be ordered separately)

3.5 Technical Features

3.5.1 PICMA® Piezo Actuators

P-63x stages are driven by PICMA® piezo actuators. PICMA® actuators have all-ceramic insulation and are therefore far superior to conventional actuators in respect to performance and lifetime. The monolithic piezoceramic block is protected against humidity and failure due to increased leakage current by a ceramic insulation layer. In this way, an especially high reliability is achieved even under extreme ambient conditions. In contrast to motorized drives, there are no rotating parts or friction. The piezo actuators are therefore backlash-, maintenance- and wear-free.

3.5.2 Flexure Guides

P-63x stages have flexure guides (flexures) for frictionless motion and high guiding accuracies.

A flexure guide is an element which is free from static and sliding friction. It is based on the elastic deformation (bending) of a solid (e.g. steel) and does not have any rolling or sliding parts. Flexure elements have a high stiffness and load capacity. Flexure guides are maintenance- and wear-free. They are 100% vacuum compatible, function in a wide temperature range and do not require any lubricants.

3.5.3 Capacitive Sensors

Capacitive sensors measure the position directly on the moving platform (direct metrology) and work without contact. Neither friction nor hysteresis interferes with the motion, which allows excellent linearity values to be achieved in combination with the high position resolution. In connection with suitable electronics, capacitive sensors achieve the best resolution, stability and bandwidth.

3.5.4 ID Chip

An ID chip is located in the Sub-D connector of the stage. When the stage is calibrated at the factory with digital electronics, the calibration data is saved together with specific product information on the ID chip. When switched on, digital electronics read the data from the ID chip of the connected stage. Stages whose ID chip contains the calibration data can therefore be connected to any suitable digital electronics without a new calibration.

For more information on the ID chip, see the manual of the controller used.

4 Unpacking

NOTICE



Mechanical overload from incorrect handling!

An impermissible mechanical overload of the moving platform of the P-63x can cause damage to the piezo actuators, sensors and flexure joints of the P-63x as well as losses of accuracy.

- Only hold the P-63x externally by the base body.

1. Unpack the P-63x with care.
2. Compare the contents against the items covered by the contract and against the packing list.
3. Inspect the contents for signs of damage. If parts are missing or you notice signs of damage, contact PI immediately.
4. Keep all packaging materials in case the product needs to be returned.

5 Installation

In this Chapter

General Notes on Installation	13
Connecting the P-63x to the Protective Earth Conductor	15
Mounting the P-63x	17
Affixing the Load.....	19

5.1 General Notes on Installation

CAUTION



Dangerous voltage and residual charge on piezo actuators!

The P-63x is driven by piezo actuators. Temperature changes and compressive stresses can induce charges in piezo actuators. After being disconnected from the electronics, piezo actuators can also stay charged for several hours. Touching or short-circuiting the contacts in the connector of the P-63x can lead to minor injuries. In addition, the piezo actuators can be destroyed by an abrupt contraction.

- Do **not** open the P-63x.
- Discharge the piezo actuators of the stage before installation:
Connect the stage to the switched-off PI controller, which is equipped with an internal discharge resistor.
- Do **not** pull out the connector from the electronics during operation.



Touching the contacts in the connector can lead to an electric shock (max. 130 V DC) and minor injuries.

- Do **not** touch the contacts in the connector.
- Secure the connector of the stage with screws against being pulled out of the controller.

NOTICE**Mechanical overload from incorrect handling!**

An impermissible mechanical overload of the moving platform of the P-63x can cause damage to the piezo actuators, sensors and flexure joints of the P-63x as well as losses of accuracy.

- Only hold the P-63x externally by the base body.

NOTICE**Damage from unsuitable cables!**

Unsuitable cables can damage the stage and the electronics.

- Only use cables provided by PI for connecting the P-63x to the electronics.

NOTICE**Damage from incorrect mounting!**

Incorrect mounting of the P-63x or incorrectly mounted parts can damage the P-63x.

- Only mount the P-63x and the loads on the mounting fixtures (holes) intended for this purpose.

NOTICE**Damage due to incorrectly tightened screws**

Incorrectly tightened screws can cause damage.

- Observe the torque range (p. 36) given for the screws used during installation.

INFORMATION

Extended cables can affect the performance of the P-63x.

- Do **not** use cable extensions. If you need longer cables, contact our customer service department (p. 31).

5.2 Connecting the P-63x to the Protective Earth Conductor


INFORMATION

In the case of P-63x stages with Sub-D connectors, ground loops can occur when the stage is grounded via its protective earth connector as well as by the shield of the connection cable for the electronics.

- If a ground loop occurs, contact our customer service department (p. 31).

INFORMATION

- Observe the applicable standards for mounting the protective earth conductor.

The P-63x is equipped with an M4 hole for fastening the protective earth conductor. This hole is located next to the cable exit and is marked with the protective earth conductor symbol  (see "Dimensions", p. 36).

Prerequisite

- ✓ You have read and understood the General Notes on Installation (p. 13).
- ✓ The stage is **not** connected to the electronics.

Tools and accessories

- Suitable protective earth conductor: Cross-sectional area of the cable $\geq 0.75 \text{ mm}^2$
- Supplied M4 protective earth screw set (p. 9) for connecting the protective earth conductor
- Suitable screwdriver

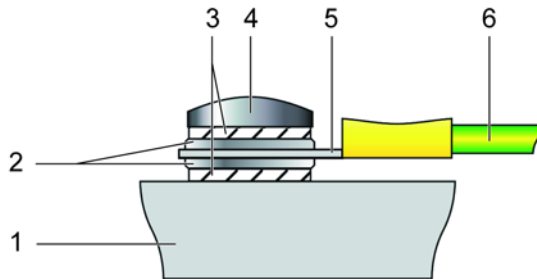


Figure 2: Mounting of the protective earth conductor (profile view)

- 1 Base body of the P-63x
- 2 Flat washer
- 3 Safety washer
- 4 Screw
- 5 Cable lug
- 6 Protective earth conductor

Connecting the P-63x to the protective earth conductor

1. If necessary, fasten a suitable cable lug to the protective earth conductor.
2. Fasten the cable lug of the protective earth conductor using the M4 screw on the protective earth connection of the P-63x as shown in the profile view.
3. Tighten the M4 screw with a torque of 1.2 Nm to 1.5 Nm.
4. Make sure that the contact resistance at all connection points relevant for mounting the protective earth conductor is $<0.1 \Omega$ at 25 A.

5.3 Mounting the P-63x

NOTICE



Warping of the P-63x due to mounting on uneven surfaces!

Mounting the P-63x on an uneven surface can warp the P-63x. Warping reduces the accuracy.

- Mount the P-63x on an even surface. The recommended evenness of the surface is $\leq 20 \mu\text{m}$.
- For applications with great temperature changes:
Only mount the P-63x on surfaces that have the same or similar thermal expansion properties as the P-63x.

NOTICE



Tensile stress on piezo actuator with vertical mounting!

When the stage is mounted vertically, tensile stress can result in particular alignments that reduces the preload of the piezo actuator and thus destroys it.

- If you want to mount the P-63x vertically, contact our customer service department (p. 31).

NOTICE



Protruding screw heads!

Protruding screw heads can damage the P-63x.

- Ensure that the screw heads do not protrude from counter-sunk holes so that they do not interfere with the stage motion.

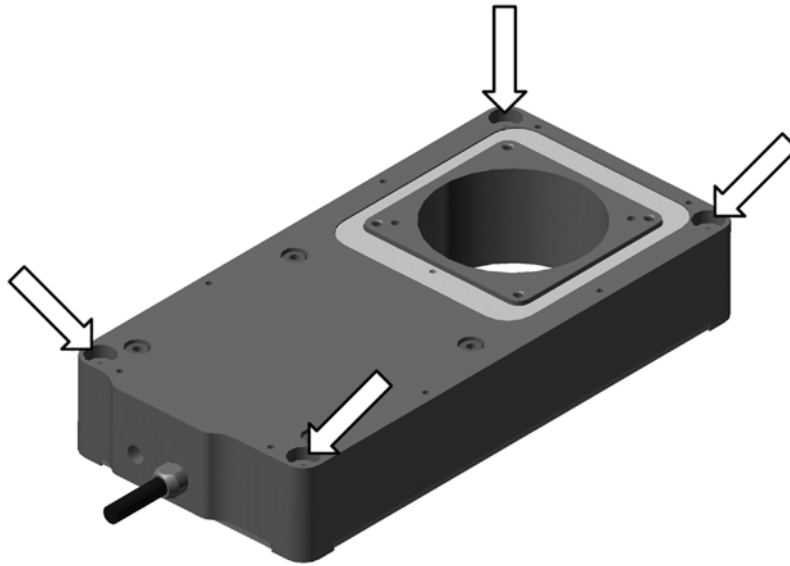


Figure 3: Mounting holes in the base body

Prerequisite

- ✓ You have read and understood the General Notes on Installation (p. 13).

Tools and accessories

- 4 included M2.5 screws and Allen wrench (p. 9)

Mounting the stage on a surface

1. Position the stage on an even surface.
2. Fasten the stage to the mounting holes (see figure) using the included screws. Observe the specified torque range (p. 36) while doing so.

5.4 Affixing the Load

NOTICE



Mechanical overload due to high torques and high loads!

When affixing the load, high torques and high loads can overload the moving platform of the P-63x. Mechanical overload can cause damage to the piezo actuators, sensors and flexure joints of the P-63x and lead to losses in accuracy.

- Observe the torque range (p. 36) given for the screws used during installation.
- Avoid torques >0.5 Nm on the moving platform.
- Do **not** exceed the maximum permissible stress and load capacities according to the specifications (p. 33).

NOTICE



Warping of the P-63x due to affixing of loads with uneven contact surface!

Affixing loads with an uneven contact surface can warp the P-63x. Warping reduces the accuracy.

- Only affix loads on the P-63x whose contact surface with the moving platform of the stage has an evenness of at least $20\ \mu\text{m}$.
- For applications with great temperature changes:
Only affix loads on the P-63x that have the same or similar thermal expansion properties as the P-63x.

NOTICE



Center of load at unsuitable position!

If the center of load is located far outside of the moving platform (e. g. high set-ups and long levers), the P-63x can be damaged from high strain on the flexure guides, high torques and oscillations.

- If the center of the load to be affixed is far above or to the side of the moving platform, adjust the controller settings before start-up or contact our customer service department (p. 31).

NOTICE**Screws that are too long!**

The P-63x can be damaged by screws that are too long.

- Note the depth of the mounting holes in the moving platform (p. 36).
- Only use screws of the correct length for the respective mounting holes.

INFORMATION

The positive direction of motion is away from the cable exit side.

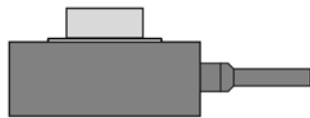
Center of load at the optimum position:

Figure 4: Example of an optimally affixed load

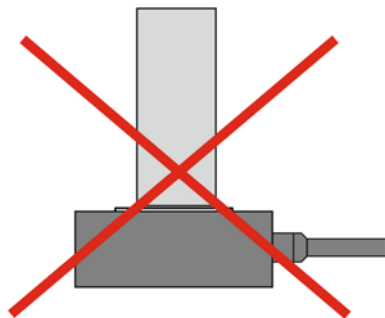
Center of load at an unsuitable position:

Figure 5: High set-up and center of load far above the moving platform

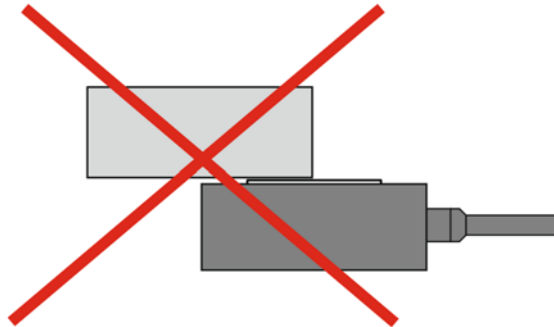


Figure 6: Long lever and center of load on the side of the moving platform

Prerequisite

- ✓ You have read and understood the General Notes on Installation (p. 13).

Tools and accessories

- Screws of appropriate size and length (p. 36)
- Suitable tools

Affixing the Load

- Only affix loads to the threaded holes (p. 36) intended for this purpose and with suitable screws. Observe the specified torque range (p. 36) while doing so.
- Affix the load so that it is centered and that the center of load is on the moving platform.

6 Start-Up and Operation

In this Chapter

General Notes on Start-Up and Operation	23
Operating the P-63x	25
P-63x entladen	25

6.1 General Notes on Start-Up and Operation

CAUTION



Risk of electric shock if the protective earth conductor is not connected!

If a protective earth conductor is not or not properly connected, dangerous touch voltages can occur on the P-63x in the case of malfunction or failure of the system. If touch voltages exist, touching the P-63x can result in minor injuries from electric shock.

- Connect the P-63x to a protective earth conductor (p. 15) before start-up.
- Do **not** remove the protective earth conductor during operation.
- If the protective earth conductor has to be removed temporarily (e. g. in the case of modifications), reconnect the P-63x to the protective earth conductor before starting it up again.

NOTICE



Destruction of the piezo actuator by electric flashovers!

The use of the P-63x in environments that increase the electrical conductivity can lead to the destruction of the piezo actuator by electric flashovers. Electric flashovers can be caused by moisture, high humidity, liquids and conductive materials such as metal dust. In addition, electric flashovers can also occur in certain air pressure ranges due to the increased conductivity of the air.

- Avoid operating the P-63x in environments that can increase the electric conductivity.
- Only operate the P-63x within the permissible ambient conditions and classifications.

NOTICE**Reduced lifetime of the piezo actuator due to permanently high voltage!**

The permanent application of a high static voltage to piezo actuators leads to a considerable reduction in the lifetime of the piezo ceramics of the actuator.

- When the P-63x is not used but the controller remains switched on to ensure temperature stability, discharge the P-63x (p. 25).

NOTICE**Operating voltages that are too high or incorrectly connected!**

Operating voltages that are too high or incorrectly connected can cause damage to the P-63x.

- Only operate the P-63x with controllers/drivers and original accessories from PI.
- Do **not** exceed the operating voltage range (p. 34) for which the P-63x is specified.
- Only operate the P-63x when the operating voltage is properly connected; see "Pin Assignment" (p. 37).

NOTICE**Uncontrolled oscillation!**

Oscillations can cause irreparable damage to the stage. Oscillations are indicated by a humming and can result from the following causes:

- A change in the load and/or dynamics requires the servo-control parameters to be adjusted.
- The stage is operated near its resonant frequency.

If you notice oscillations:

- In closed-loop operation, immediately switch off the servo mode.
- In open-loop operation, immediately stop the stage.

INFORMATION

The positive direction of motion is away from the cable exit side.

INFORMATION

Sound and vibration (e.g. footfall, impacts) can be transmitted to the stage and can affect its performance with regard to position stability.

- Avoid transmitting sound and vibration while the stage is being operated.

6.2 Operating the P-63x

- Follow the instructions in the manual of the used controller for start-up and operation of the P-63x.

6.3 Discharging the P-63x

The P-63x must be discharged in the following cases:

- Before installation
- If the P-63x is not used but the controller remains switched on to ensure temperature stability
- Before demounting (e.g. before cleaning and transporting the P-63x and for modifications)

The P-63x is discharged through the internal discharge resistor of the controller from PI.

Discharging a P-63x that is connected to the controller

In closed-loop operation:

1. Switch off the servo mode on the controller.
2. Set the piezo voltage to 0 V on the controller.

In open-loop operation:

- Set the piezo voltage to 0 V on the controller.

Discharging a P-63x that is not connected to the controller

- Connect the stage to the switched-off controller from PI.

7 Maintenance

In this Chapter

General Notes on Maintenance.....	27
Cleaning the P-63x	27

7.1 General Notes on Maintenance

NOTICE



Misalignment from loosening screws!

The P-63x is maintenance-free and achieves its positioning accuracy as a result of the optimum alignment of mechanical components and piezo actuators. Loosened screws cause a loss in positioning accuracy.

- Only loosen screws according to the instructions in this manual.
- Do **not** open the P-63x.

7.2 Cleaning the P-63x

Prerequisites

- ✓ You have discharged the piezo actuators of the P-63x (p. 25).
- ✓ You have disconnected the P-63x from the controller.

Cleaning the P-63x

- Clean the surfaces of the P-63x with a cloth slightly dampened with a mild cleanser or disinfectant (e.g. alcohol or isopropanol).
- Do **not** do any ultrasonic cleaning.

8 Troubleshooting

Problem	Possible Causes	Solution
No or limited motion	The cable is not connected correctly	➤ Check the cable connections.
	Excessive load	➤ Do not exceed the maximum permissible stress and load capacities according to the specifications (p. 33).
	Zero shift of the sensor for the following reasons: <ul style="list-style-type: none"> ▪ Load applied in direction of motion ▪ Ambient/operating temperature of the stage far above or below calibration temperature (21°C to 24°C) 	➤ Perform a zero-point adjustment of the sensor (see controller manual).
Reduced accuracy	Warping of the base body or the moving platform	<ul style="list-style-type: none"> ➤ Only mount the P-63x on surfaces with the following characteristics: <ul style="list-style-type: none"> – Evenness of at least 20 µm – The thermal expansion properties are similar to those of the P-63x (e. g. surfaces made of aluminum). ➤ Only affix loads with the following characteristics on the P-63x: <ul style="list-style-type: none"> – The contact surface of the load has an evenness of at least 20 µm. – The thermal expansion properties are similar to those of the P-63x (e. g. loads made of aluminum).

Problem	Possible Causes	Solution
The stage starts oscillating or positions inaccurately	Servo-control parameters incorrectly set because e. g. the load was changed	<ol style="list-style-type: none"> 1. Immediately switch off the servo mode of the corresponding stage axes. 2. Check the settings of the servo-control parameters on the controller. 3. Adjust the servo-control parameters on the controller according to the load change.
	Open-loop operation near the resonant frequency	➤ In open-loop operation, only operate the stage with a frequency that is below the resonant frequency.

If the problem that occurred with your system is not listed in the table above or cannot be solved as described, contact our customer service department (p. 31).

9 Customer Service

For inquiries and orders, contact your PI sales engineer or send us an e-mail (info@pi.ws).

If you have questions concerning your system, have the following information ready:

- Product codes and serial numbers of all products in the system
- Firmware version of the controller (if present)
- Version of the driver or the software (if present)
- Operating system on the PC (if present)

The latest versions of the user manuals are available for download (p. 3) on our website.

10 Technical Data

In this Chapter

Specifications	33
Dimensions	36
Torque for Stainless Steel Screws (A2-70)	36
Pin Assignment.....	37

10.1 Specifications

10.1.1 Data Table




	P-630.XCD	P-631.XCD	Unit
Active axes	X	X	
Motion and positioning			
Integrated sensor	Capacitive	Capacitive	
Open-loop travel, -20 to 120 V	45	90	μm
Closed-loop travel	40	80	μm
Open-loop resolution	0.1	0.1	nm
Closed-loop resolution	0.2	0.2	nm
Closed-loop nonlinearity	0.02	0.02	%
Repeatability over the entire travel range	±2	±3	nm
Pitch / yaw	±5	±5	μrad
Straightness / flatness	50	50	nm
Mechanical properties			
Stiffness in motion direction	5.5	5	N / μm
Unloaded resonant frequency	3250	2850	Hz
Resonant frequency @ 60 g	1600	1200	Hz
Push / pull force capacity in motion direction	10	10	N
Load capacity	10	10	N

Drive properties			
Piezo ceramic	PICMA® P-887	PICMA® P-885; P-887	
Electrical capacitance	6.4	12.6	µF
Dynamic operating current coefficient	20	20	µA / Hz × µm
Miscellaneous			
Operating temperature range	0 to 40	0 to 40	°C
Material	Aluminum	Aluminum	
Dimensions	102 mm × 50 mm × 18 mm	102 mm × 50 mm × 18 mm	
Mass	300	320	g
Cable length	1.5	1.5	m
Sensor / voltage connection	Sub-D special connector (single-axis, capacitive)	Sub-D special connector (single-axis, capacitive)	
Recommended controller / amplifier	E-709.CR cost-efficient digital controller E-709.CHG digital controller for high dynamics and quick step-and-settle E-753.1CD digital controller for high resolution and linearity	E-709.CR cost-efficient digital controller E-709.CHG digital controller for high dynamics and quick step-and-settle E-753.1CD digital controller for high resolution and linearity	

Ask about custom designs!

10.1.2 Maximum Ratings

P-63x stages are designed for the following operating parameters:

Stage	Maximum Operating Voltage	Maximum Operating Frequency (Unloaded)	Maximum Power Consumption
			
P-630.XCD	-20 to +120 V	1080 Hz	8 W
P-631.XCD	-20 to +120 V	950 Hz	19 W

10.1.3 Ambient Conditions and Classifications

The following ambient conditions and classifications must be observed for the P-63x:

Area of application	For indoor use only
Maximum altitude	2000 m
Air pressure	1100 hPa to 0.1 hPa (corresponds to roughly 825 Torr to 0.075 Torr)
Relative humidity	Highest relative humidity 80% for temperatures up to 31°C Decreasing linearly to 50% relative humidity at 40°C
Operating temperature	0°C to 40°C
Storage temperature	-20°C to 80°C
Transport temperature	-25°C to 85°C
Overvoltage category	II
Protection class	I
Degree of pollution	1
Degree of protection according to IEC 60529	IP20

10.2 Dimensions

Dimensions in mm. Note that the decimal places are separated by a comma in the drawings.

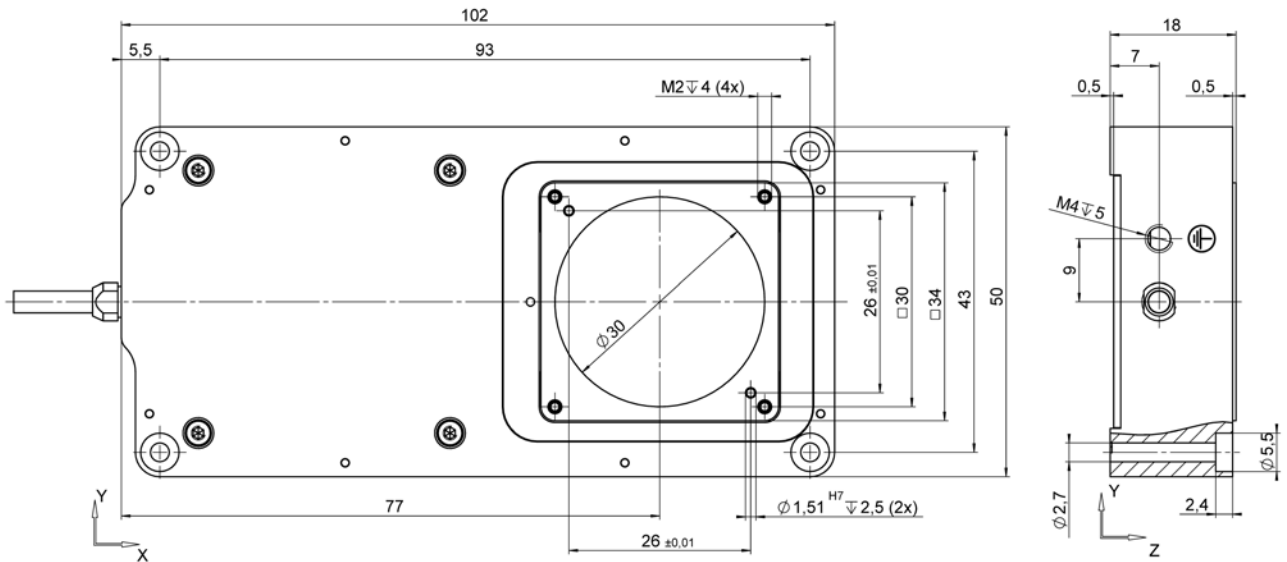


Figure 7: P-63x

10.3 Torque for Stainless Steel Screws (A2-70)

Screw Size	Minimum Torque	Maximum Torque
M6	4 Nm	6 Nm
M5	2.5 Nm	3.5 Nm
M4	1.5 Nm	2.5 Nm
M3	0.8 Nm	1.1 Nm
M2.5	0.3 Nm	0.4 Nm
M2	0.15 Nm	0.2 Nm
M1.6	0.06 Nm	0.12 Nm

10.4 Pin Assignment

7W2 Sub-D mix connector

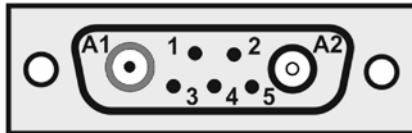


Figure 8: Sub-D Mix connector 7W2: Front side with connections

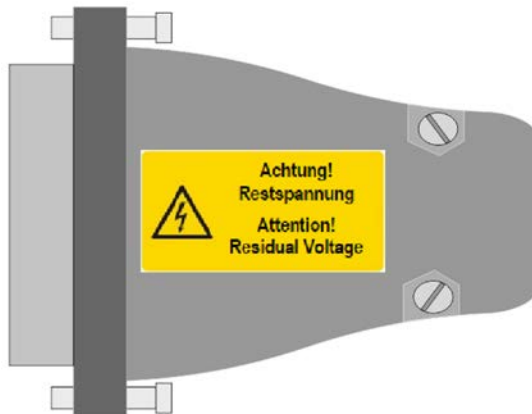


Figure 9: Sub-D mix connector: Exemplary top view

Pin	Signal	Function
A1	PZT	Piezo voltage
A2	Probe	Probe sensor signal (moving part of the capacitive sensor)
1	Data ID chip	Data cable for ID chip
2	GND target and ID chip	Ground of target and ID chip
3	GND PZT	Ground of piezo voltage
4	Free	-
5	Target	Target sensor signal (non-moving part of the capacitive sensor)
Case	-	Shield

11 Old Equipment Disposal

In accordance with the applicable EU law, electrical and electronic equipment may not be disposed of with unsorted municipal wastes in the member states of the EU.

When disposing of your old equipment, observe the international, national and local rules and regulations.

To meet the manufacturer's product responsibility with regard to this product, Physik Instrumente (PI) GmbH & Co. KG ensures environmentally correct disposal of old PI equipment that was first put into circulation after 13 August 2005, free of charge.

If you have old PI equipment, you can send it postage-free to the following address:

Physik Instrumente (PI) GmbH & Co. KG
Auf der Römerstr. 1
D-76228 Karlsruhe, Germany



12 EC Declaration of Conformity

For the P-63x, an EC Declaration of Conformity has been issued in accordance with the following European directives:

2006/95/EC, Low Voltage Directive

2004/108/EC, EMC Directive

2011/65/EU, RoHS Directive

The applied standards certifying the conformity are listed below.

Electromagnetic Emission: EN 61000-6-3:2007, EN 55011:2009

Electromagnetic Immunity: EN 61000-6-1:2007

Safety (Low Voltage Directive): EN 61010-1:2010

